

MODEL 525

CHAIN DRIVEN LIVE ROLLER

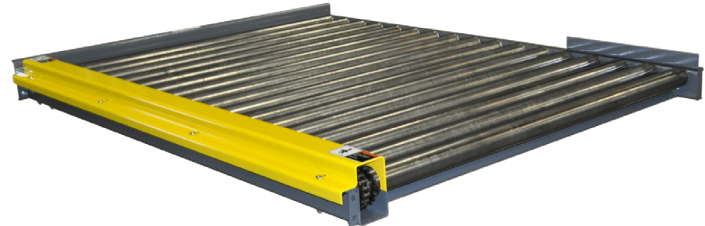

The **Model 525 Chain Driven Live Roller conveyor** from RSI, Inc. is designed to handle heavy loads such as pallets, skids or drums. The unit incorporates a number 50 chain with a roll-to-roll drive. The frame is a heavy formed 7 gauge construction with a one piece chain guard. Rollers are 2-1/2" diameter x 11 gauge (**580 lb. capacity**). The standard drive is a 3/4 H.P. for 30 F.P.M. roller speed. A wide range of standard effective widths are available. Standard roller spacings are 2-13/16", 3-7/16", 4-3/8", 5", and 5-15/16". Floor supports are optional. The Model 525 comes in lengths to suit with a minimum length of 4' long. Consult the factory for further details.



MODEL 525 CHAIN DRIVEN LIVE ROLLER CONVEYOR SPECIFICATIONS		
	Standard	Options
Effective Widths	13" to 40"	Specify up to 40" E.W.
Lengths	5' min.	3' min., max. based on application
Roller Size	2 1/2" Dia. x 11 ga. with 11/16" hex shaft - 580 lb. roller cap.	
Roller Center	5"	2-13/16", 3-7/16", 4-3/8", 5-15/16", 10"
Frame	Formed 7 ga.	
Drive	3/4 H.P. 230/460/3/60	1, 1-1/2, 2, 3 H.P. 230/460/3/60, severe duty, inverter duty, brake motor
Chain Drive	#50	#60 available
OPTIONAL		
Roller Space - Consult factory, Roller Center - Consult Factory, Drive locations: as needed, Galvanized or stainless construction, H. P. , Speeds, Variable speed, Controls, Coated rollers, Paint, 2 or 3 strand chain transfers, Pallet lifts, Pallet jack plates for side or end load, "C" Face brake and Fixed end stop, Rollers set low, UHMW sleeves, Accumulation sleeves, Knee braces, Air operated blade stop, Supports - 6" @ #8.2 structural channel,		

NOTE: Specifications subject to change without notice

MODEL 525

CHAIN DRIVEN LIVE ROLLER CONVEYOR

FIGURE "A"

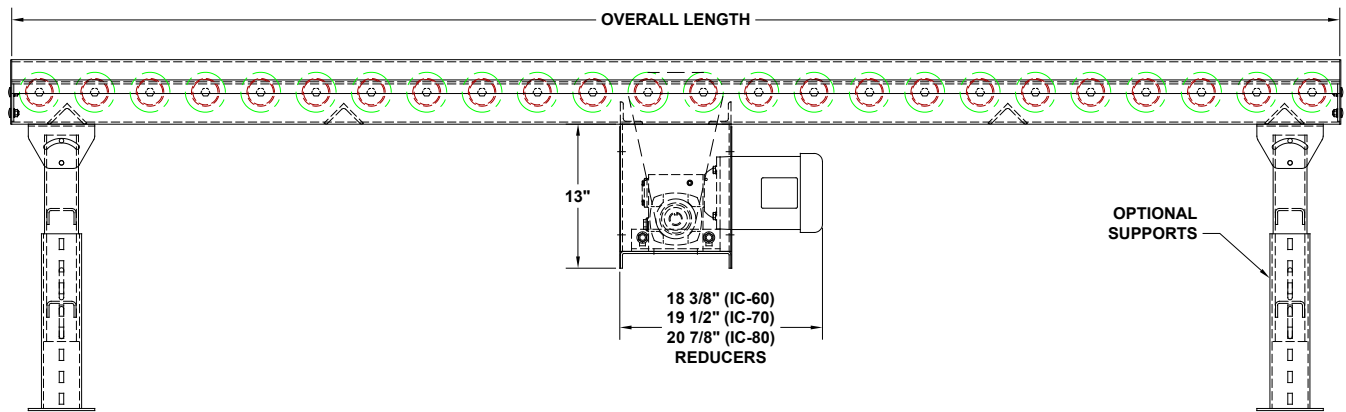

FIGURE "B"

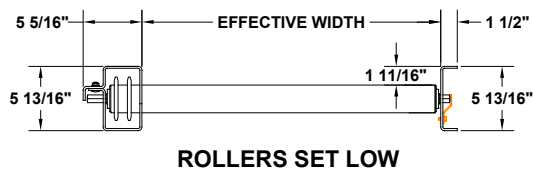

FIGURE "C"

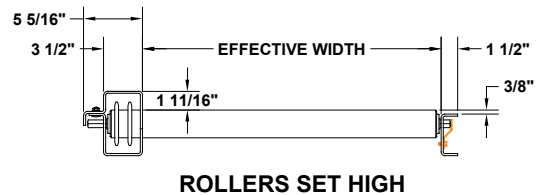

FIGURE "D"

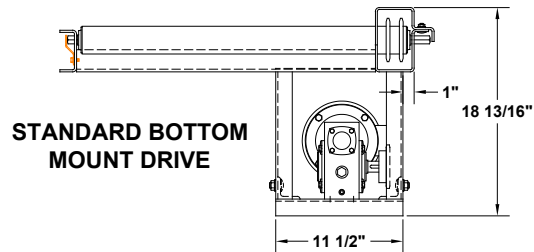

FIGURE "E"

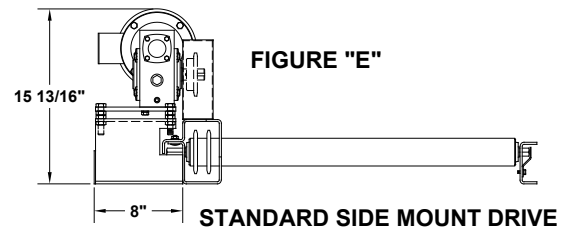

FIGURE "F"

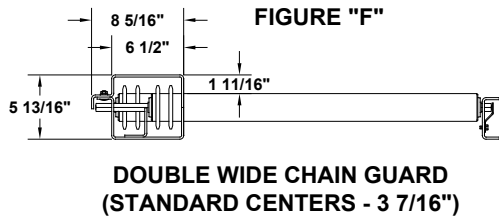

FIGURE "G"

