

# P227 Concept Layout

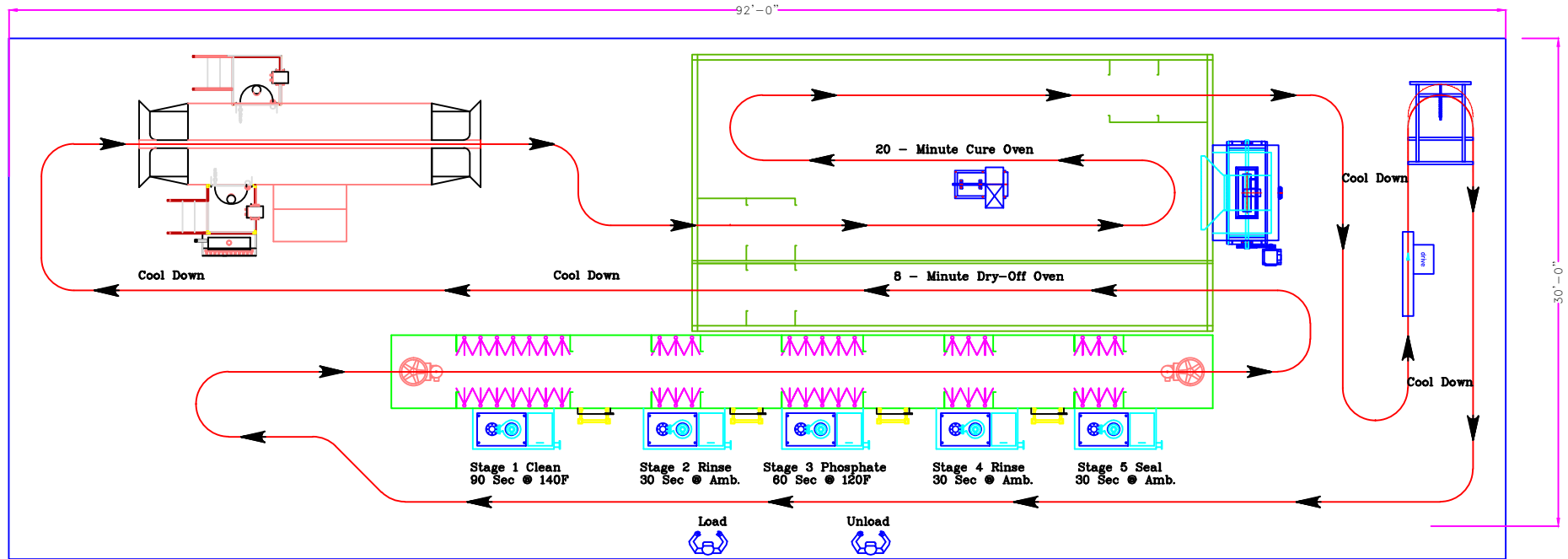

THIS DRAWING IS THE PROPERTY OF AMERICAN INDUSTRIAL SALES, LLC AND IS SUBJECT TO RETURN UPON REQUEST. IT IS TO BE USED ONLY FOR THE PURPOSE FOR WHICH IT WAS EXPRESSLY LOANED AND IS NOT TO BE USED IN ANY WAY DETRIMENTAL TO THE INTEREST OF THIS FIRM.

SCALE		NONE		American Industrial Sales, LLC	
DWG NUMBER REF		2011 709 CL3		920-361-5208	
DATE		11/17/11		JOB # 2011-709	
DRAWN BY		NT		ITEM # Powder Coating System	
CHECKED BY		CUST		Dennis Russell	
		DRAWING NUMBER		Russell\2011 709 CL3	

## SYSTEM DESIGN DATA:

- Part Opening:  
- 2'-6" wide x 6'-0" high
- Product Dimension:  
- 2'-0" wide x 5'-0" high x 6'-0" long
- Product Weight:  
- 100 lbs per part
- Line Speed:  
- 4 FPM
- Conveyor:  
- 3" Enclosed Track

## Product

